



INSTALLATION MANUAL

P4 Primary Filter

Model: P4-GN

Basic Requirements For P4 Primary Filter Installation

1. Product Description:

The gill net backwash pre-filter is primarily used to intercept pollutants such as particulate impurities, sediment, rust, and floating debris in water. It serves a protective role in downstream pipelines, water purifiers, water heaters, wall-mounted stoves, washing machines, showers, and other water-related equipment.

2. Key Skills Required:

2.1. A qualified plumbing professional

2.2. **Specialised Equipment Required:** Welding equipment & Face mask protector
Hack saw/angle grinder, Wrench, Screwdriver

3. Product Features:

3.1. Utilises new fish gill biomimetic microfiltration + mesh membrane fine filtration Technology, to intercept large particulates such as rust, sediment, suspended organic~, and non-organic solids, etc. in the mains water;

3.2. The filter screen can be cleaned by backwashing without disassembly;

3.3. Features a super large water capacity, using 316L food-grade stainless steel precision mesh + food-grade PP fish gill biomimetic laminated mesh;

3.4. The core components are specifically crafted from imported materials, ensuring robust compressive strength, as well as safety and reliability;

3.5. Equipped with professional tooth-shaped self-locking thread for enhanced safety and reliability;

3.6. Produced through an integrated injection molding process, this product is completely lead-free, while prioritising Health and Safety criteria to provide a safer user experience.

4. Precautions:

4.1. Installation, debugging, and maintenance should be conducted by a qualified professional;

4.2. This product is designed for indoor installation and should be protected from exposure to high humidity/damp; ultraviolet rays, heat sources, fuel, and various other chemicals to the greatest extent possible;

4.3. Specifically designed for use with municipal tap water within a temperature range of 5-38°C; avoid use with corrosive liquids or wastewater;

4.4. During installation, ensure that the water flow direction indicated on the product valve body aligns with the mains-water flow direction;

4.5. Ensure the installation position is conducive to efficient filtration.

4.6. While water quality is different for different regions, it is essential to 'flush' the Filter every 30 days;

4.7. When performing routine cleaning and maintenance, take special care to protect all components;

5. Flushing Protocol

Step 1: Pre-Rinse

Submerge in tap water for 90 minutes, then filter and rinse with tap water for 2 hours. This process involves alternating the drain action as per the manual, running it for 15 seconds every 30 minutes.

Step 2: Initial Sewage Flush

After installing your new P4 Primary Filter, repeat the above steps for sewage flushing;

Dormant Periods:

After every 5 hours of shutdown or longer, drain the water for 2 minutes before use.

The 'grey' discharged water is suitable for the garden, pot plants or household cleaning but not recommended for drinking.

After the 2minute, drain is complete, resume using as normal. Repeat this operation cycle 10 times as described above. Once 10 cycles have been completed, drain the water for the final time and resume use as normal.

Inspect the Filter connections regularly to check for leaks.

When the property is not inhabited for extended periods, we recommend closing the mains water inlet valve.

6. Product Description

Product Name	Primary Filter	Filtering Accuracy	40µm
Product Model	P4-GN	Applicable Water Source	Municipal tap water
Ambient Water Temperature	5~38°C	Purified Water Flow Rate	6m ³ /h
Applicable Water Pressure	0.1-1Mpa	Connection Size	DN20/DN25
Waste Water Drainage Space	>300mm		
Effluent Quality	Complies with the requirements of the "General Water Quality Processors" (2001) in accordance with the Health & Safety, and Functional Evaluation Specifications for Drinking Water Quality Processors		

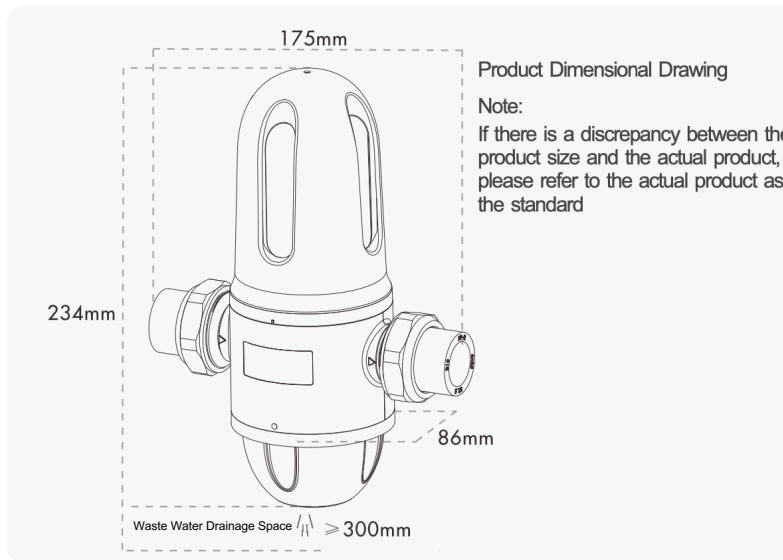

7. Product Components

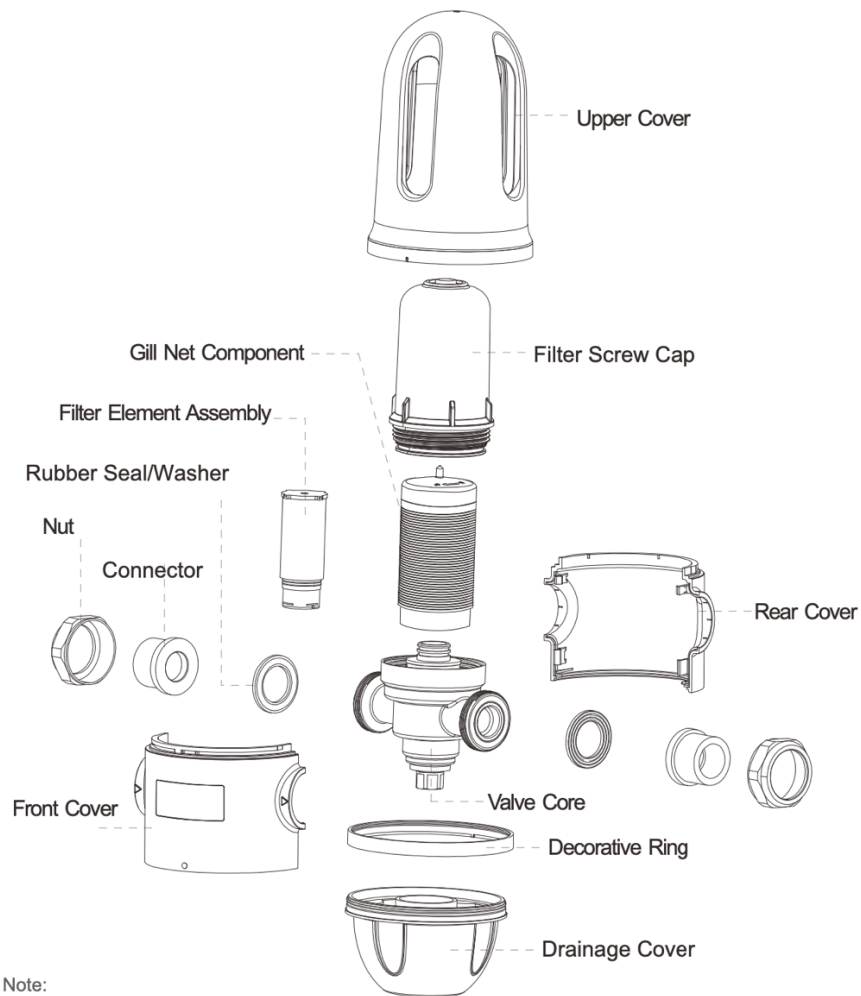

Note:
The diagram is not drawn to scale & physical components may differ in size

8. Product Installation

8.1. Configuration Of Product Installation

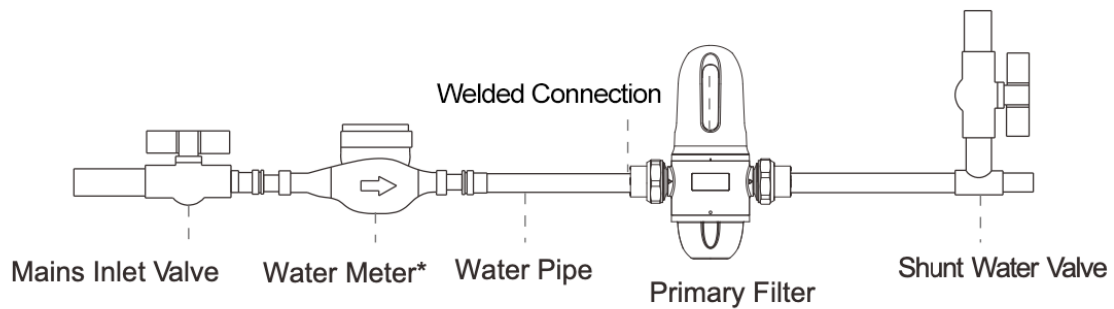

Turn off the water inlet valve and then drain the remaining water in the pipeline. When installing, ensure that the water flow direction marked on the valve body aligns with the water flow direction in the pipeline.

After installing this Primary Filter, the filter components must be kept vertical.

Installation requires the expertise of professional personnel, and it is essential to verify that all the components are fully present and intact (see components section page 2) before commencing installation.

8.2. PPR pipeline installation:

- 8.2.1. Install special welding equipment.
- 8.2.2. Carefully pre-measure the installation site in accordance with the pre-measured width of the P4-GN-filter;
- 8.2.3. Make the necessary incisions into the water inlet pipe accordingly;
- 8.2.4. Insert the PPR joint into the PPR joint nut first, and use a welding machine to weld the PPR joint on the machine and the PPR pipe on the pipeline;
 - 8.2.4.1. Repeat the same process of welding the other end of the PPR pipe;
 - 8.2.4.2. After installation, carefully inspect the welded connections for any signs of drips and/or leaks.

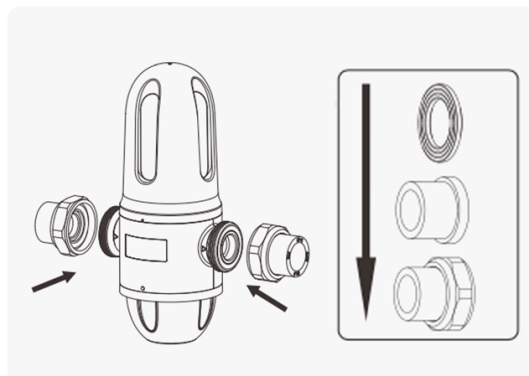

9. Product Instructions

9.1. Blowdown Operation Procedure

9.1.1. After the installation is complete, open the mains inlet valve and initiate Flushing.

9.1.2. Prior to Flushing, ensure you have a suitably shaped vessel for collecting the flushed wastewater. This 'grey' water may be used for watering the garden or potted plants, but is not suitable for consumption;

9.1.3. To empty the collected water, and/or clean the filter, unscrew the filter discharge cover by turning it 90° in a clockwise direction;

9.1.4. While municipal water quality differs in various regions, it is recommended to rinse bi-monthly (every 15 days) by turning the sewage on and off three times, rinsing for 30second cycles each time;

9.1.5. We recommend the filter screen is cleaned every 8-12months, by professional maintenance staff;

9.1.6. During routine cleaning and maintenance, ensure all components are well protected (use original accessories for maintenance).

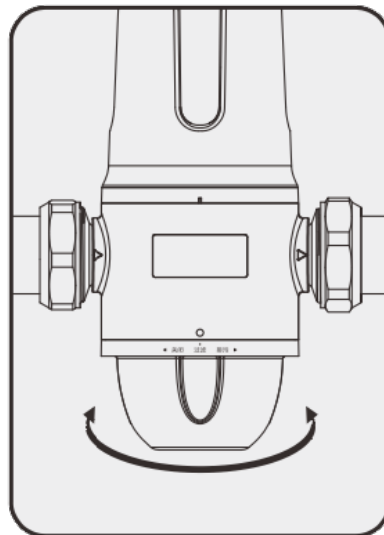

9.2. Filter Screen: Disassembly & Cleaning

It is advisable to engage professional personnel for disassembly and cleaning.

If normal scraping or flushing fails to remove debris from the filter screen, impacting water usage, it is recommended to disassemble and clean the filter screen components.

To achieve this:

1. Use a wrench to unscrew the filter bottle in a clockwise direction
2. Remove the filter element component, rotate the filter element cover clockwise to detach it, then lower the impeller and extract the filter element (refer to the schematic diagram on page 4 for detailed instructions)
3. Clean the lamination and the surface of the filter element to remove any embedded debris.

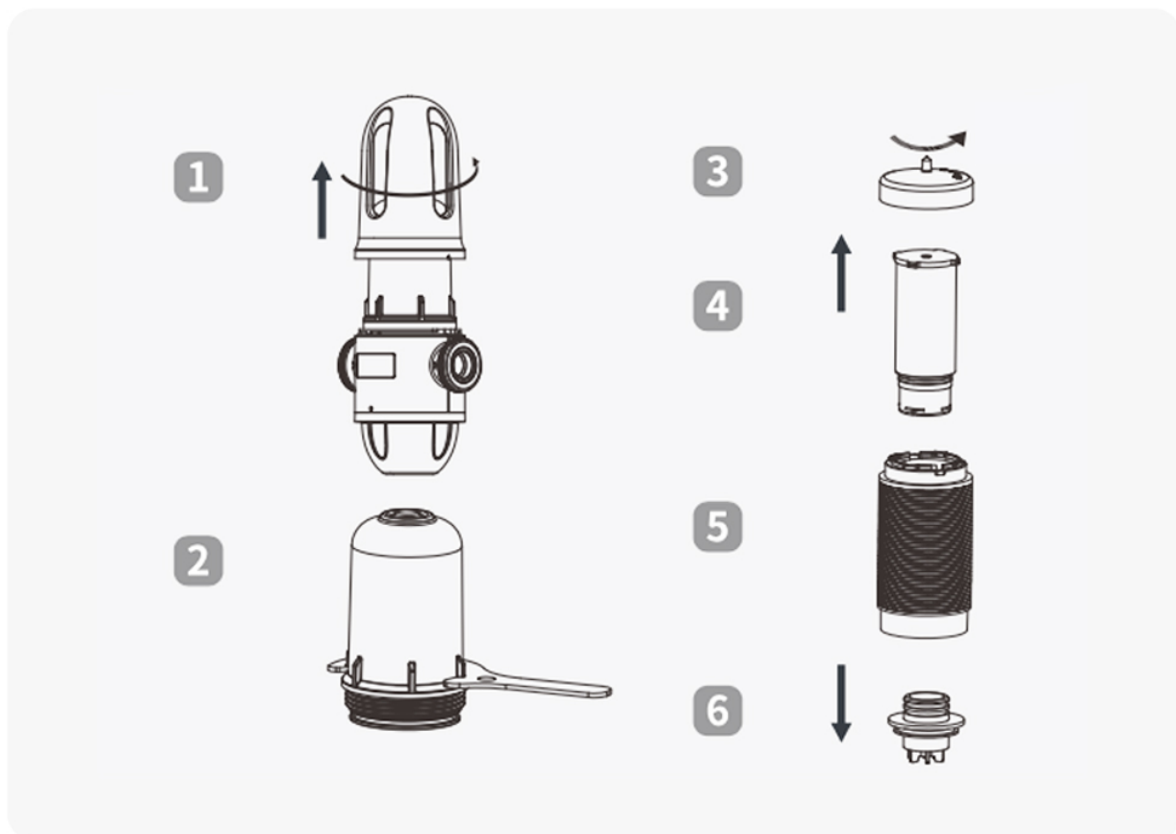

9.3. Reassemble The Scraping And Filtering Components

Fit the filter element into the bracket hole, fit the impeller upwards into the inner hole of the filter element,

Firmly press the impeller into place

Place the Filter element cover over the Filter element & turn it in an anti-clockwise direction to tighten

Using a spanner, turning in an anti-clockwise direction to tighten the filter bottle onto the threaded Filter head, and ensure the reconnection is securely fastened.

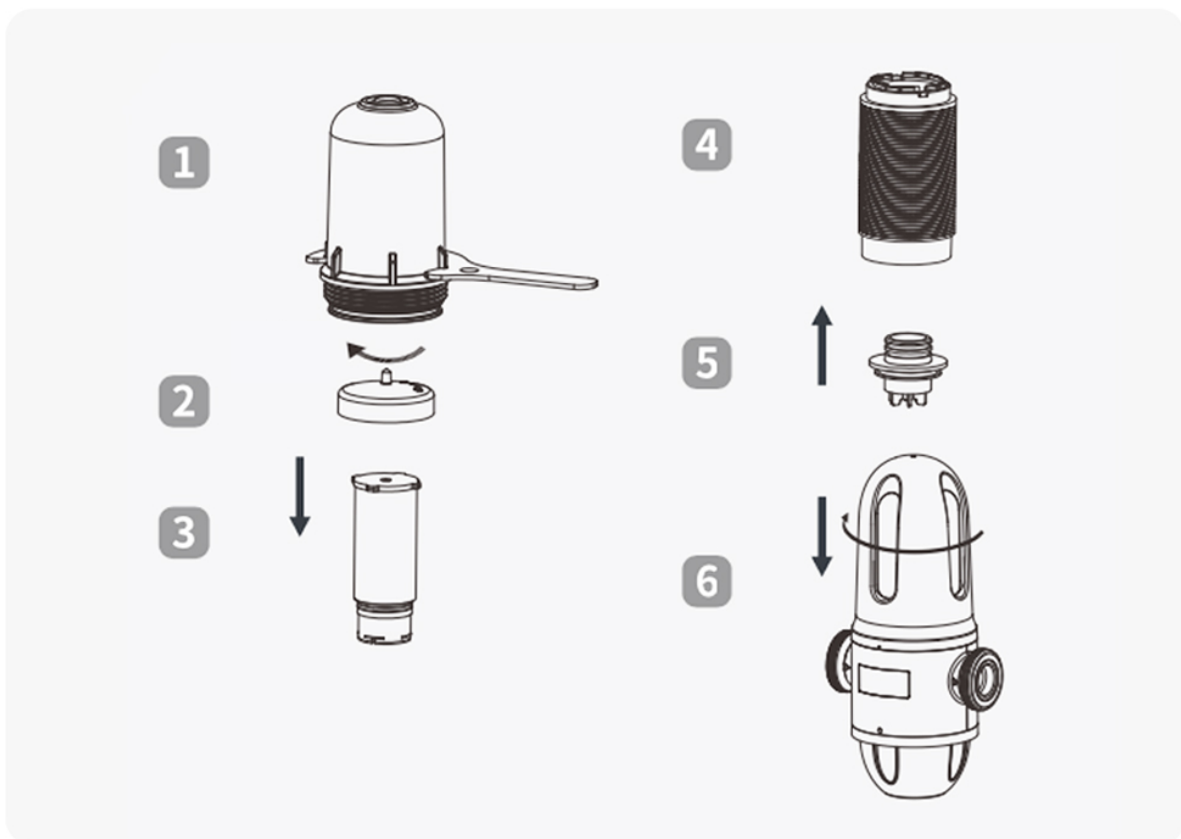

10. Fault Analysis & Trouble-Shooting

Fault / Issue	Checklist of Possible Reasons	Options & Solution
No water flow	A. Is there water in the water value B. Is the main inlet value open	A. Open the mains inlet value B. Wait for water supply
Low effluent flow rate	A. Is the main inlet value fully open B. The surface of the filter screen is partially blocked	A. Fully Open the main inlet valve B. Flush the filter screen & remove any debris
There is a water drip/leak at the welded joint	A. Have the filter components accidentally come apart B. Are there any loose parts C. Insufficient plumbing tape used on threaded connections D. Damaged or worn rubber washers at water leakage points	A. Check if rubber seal/washer is misaligned or detached. If so, replace rubber seal /washer* B. Retighten the threaded joint with the use of a wrench C. Reapply fresh tape & tighten D. See A*
Pressure values not displayed	Pressure gauge damaged	Replace the pressure gauge

11. Packing List

- 1 Primary Filter
- 1 Installation Manual
- 1 Pack of Filter Components

DISCLAIMER

Hydrogen Water Filters™ supplies fully Certified and Tested products. To validate the product Warranty, we recommend the installation process is carried out by a qualified plumbing professional. Furthermore, we cannot be held responsible for any damages to this product, or other machines/appliances and/or plumbing components; this extends to personal injury and liability, property damage/losses and/or environmental damage, etc., resulting from unauthorised Installation of this product, debugging, component replacement, etc. If this product was installed by a plumbing professional and you have any concerns, please immediately contact our support team at support@hydrogen-therapy.co.uk